

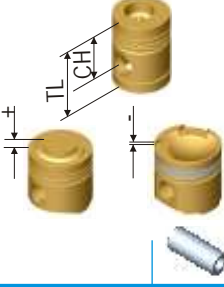













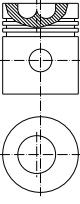
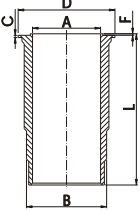
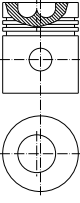
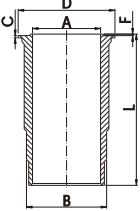
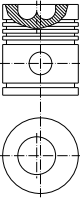
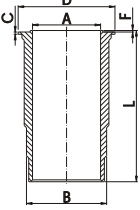

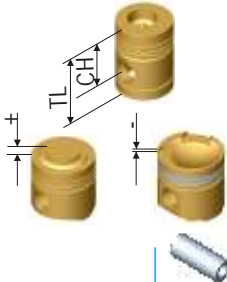

	No	Ø mm			Type				
<b>VOLVO</b>									
<b>Diesel Motor:</b> TD 61 F/G, 5480 cm <sup>3</sup> , 152 KW (207 PS), 16:1 Direct Injection, Turbocharge <b>Vehicle:</b> BMC Yavuz, FL 616 1986...	6	98.425	79.40 -21.80 124.40 	40.00 x 77.30	ST	2.385 R CRP 3.160 T CRP 4.747 C CRP	98.425	P 67010 00	 A=98.425 B=110.00 L=234.50 D=119.10 C=11.61 F=0.74
<b>Diesel Motor:</b> TD 60 B, 5480 cm <sup>3</sup> , 125-132 KW (174-180 PS), 16:1 Direct Injection Turbocharge <b>Vehicle:</b> BMC Yavuz, F 613, F 614, B 6 F, F 616, <b>Diesel Motor:</b> TD 60 C, 5480 cm <sup>3</sup> , 108-113 KW (147-154 PS), 17:1 Direct Injection Turbocharge <b>Vehicle:</b> F 610, F 611 1978...1985	6	98.425	79.40 -21.80 124.40 	40.00 x 77.30	ST	2.385 R CRP 3.160 T CRP 4.747 C CRP	98.425	P 67012 00	 A=98.425 B=110.00 L=234.50 D=119.10 C=11.61 F=0.74
<b>Diesel Motor:</b> D 70 A, 6700 cm <sup>3</sup> , 106 KW (144 PS), 17:1 <b>Vehicle:</b> F 86, N 86 1965...1971 <b>Diesel Motor:</b> D 70 B, 6700 cm <sup>3</sup> , 110,5 KW (150 PS), 17:1 <b>Vehicle:</b> F 86, N 86 1971...1975	6	104.775	88.45 -26.70 141.05 	45.00 x 85.80	ST	2.385 R CR 3.160 T 3.160 T 4.747 BS 4.747 BS	104.775	P 67020 00	 A=104.775 B=117.00 L=257.00 D=127.00 C=11.66 F=0.74

	 No	 mm	 Type				
--	---	---	---	--	---	---	---

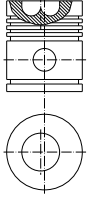
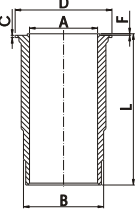
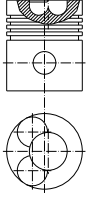
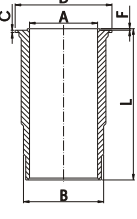
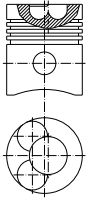
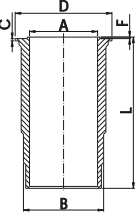

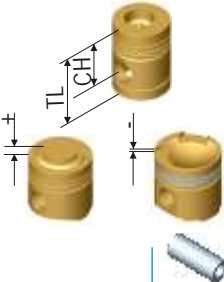

## VOLVO

<p><b>Diesel Motor:</b> TD 70 A, 6700 cm<sup>3</sup>, 136 KW (185 PS), 15.5:1 <b>Vehicle:</b> B 54, B 57, F 86, FB 86, N 86, N 7, Dumper 3500 1965...1971</p> <p><b>Diesel Motor:</b> TD 70 B/C, TMD 70 B, 6700 cm<sup>3</sup>, 152.5 KW (207 PS), 15.5:1, Turbocharge <b>Vehicle:</b> F 86, FB 86, N 86, N 7 1971...1975</p>	6	104.775	88.45 -26.20 141.05  	45.00 x 85.80	ST	2.385 R CR 3.160 T 3.160 T 4.747 C CR 4.747 BS	104.775	P 67022 00	 A=104.775 B=117.00 L=257.00 D=127.00 C=11.66 F=0.74
<p><b>Diesel Motor:</b> TD 70 E, 6700 cm<sup>3</sup>, 155 KW (210 PS), 14.5:1, Turbocharge <b>Vehicle:</b> F 86, TF 86 T, N 725, TF 86 DTC, TN 7, B 57, Dumper 4500 1974...1978</p>	6	104.775	88.45 -26.15 -1.00 141.05  	45.00 x 85.80	ST	2.385 R CR 3.160 T 3.160 T 4.747 C CR	104.775	P 67024 00	 A=104.775 B=117.00 L=257.00 D=127.00 C=11.66 F=0.74
<p><b>Diesel Motor:</b> D 100 A/B, MD 100 B, HD 100 A, 9600 cm<sup>3</sup>, 122-147 KW (166-200 PS) 17:1 <b>Vehicle:</b> N 88, F 88, LN 88, LF 88 1965...</p> <p><b>Diesel Motor:</b> THD 100 A, TMD 100 A, 9600 cm<sup>3</sup>, 139-191 KW (220-260 PS), 17:1, Strok: 140mm, Turbocharge <b>Vehicle:</b> B 58, B 59 1965...1983</p>	6	120.65	109.45 -29.15 -1.00 166.45  	52.00 x 106.00	ST	2.385 R CR 3.160 T 3.160 T 4.747 C CR	120.65	P 67030 00	 A=120.65 B=134.00 L=294.00 D=147.00 C=11.74 F=0.80

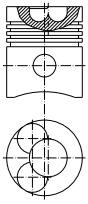
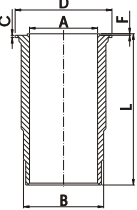
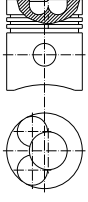
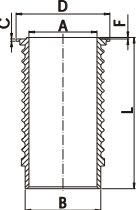
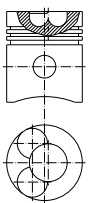
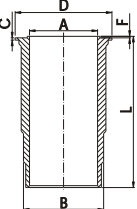
	 No    Ø mm		Type				
--	--	---	------	--	---	---	---

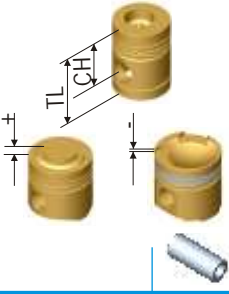
**VOLVO**

<p><b>Diesel Motor:</b> TD 100 A, 9600 cm<sup>3</sup>, 169-191 KW (230-260 PS), 15-17:1, Strok:140mm, Turbocharge <b>Vehicle:</b> N 88, F 88, NB 88, FB 88, N 10 1965...1970</p> <p><b>Diesel Motor:</b> THD 100 D, 9600 cm<sup>3</sup>, 169-178-191 KW (230-242-260 PS), 15-17:1, Strok:140mm Turbocharge <b>Vehicle:</b> B 10, B 58, B 59, 300 CH, 400 CH 1975...1982</p>	6	120.65	109.45 -27.65 -1.00 -1.30 166.45	 52.00 x 106.00	ST	2.385 R CR 3.160 T 3.160 T 4.747 C CR	120.65	P 67032 00	 A=120.65 B=134.00 L=294.00 D=147.00 C=11.74 F=0.80
<p><b>Diesel Motor:</b> TD 100 B, 9600 cm<sup>3</sup>, 207-220 KW (280-300 PS), 12.5:1, Turbocharge <b>Vehicle:</b> F 10-46, F 10-49, F 10-52, F 10-56, F 1020/38, 1974...1981</p>	6	120.65	109.40 -28.00 -2.90 166.40	 52.00 x 106.00	ST	2.385 R CR 3.160 T CR 4.747 C CR	120.65	P 67034 00	 A=120.65 B=134.00 L=294.00 D=147.00 C=11.74 F=0.80
<p><b>Diesel Motor:</b> TD 100 BG, 9600 cm<sup>3</sup>, 14.3:1, Turbocharge, 1981...</p>	6	120.65	109.40 -28.00 -2.90 166.40	 52.00 x 106.00	ST	2.385 R CR 3.160 T CR 4.747 C CR	120.65	P 67036 00	 A=120.65 B=134.00 L=296.00 D=147.00 C=11.52 F=3.48

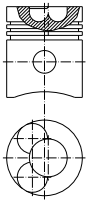
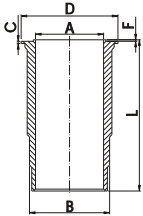
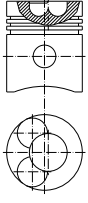
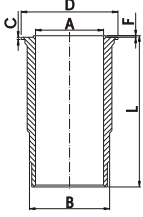
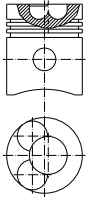
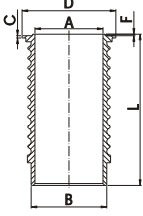
	No	Ø mm		Type					
<b>VOLVO</b>									
<b>Diesel Motor:</b> TD 100 G/GA, 9599 cm <sup>3</sup> , 200 KW (272 PS), 14.3:1 Turbocharge <b>Vehicle:</b> F 10, N 10 1981...1986  <b>Diesel Motor:</b> TD 101 F/FA/G/GA, 9599 cm <sup>3</sup> , 220 KW (299 PS), 14.3:1, Turbocharge, LLK <b>Vehicle:</b> F 10 Intercooler, N 10 Intercooler, 1983...1986	6	120.65	109.40 -23.15 -1.90 166.40  	52.00 x 106.00	ST	2.385 R CR 3.160 T CR 4.747 C CR	120.65	P 67038 00	  A=120.65 B=134.00 L=296.00 D=147.00 C=11.52 F=3.48
<b>Diesel Motor:</b> TD 101 F/FA/G/GA, 9599 cm <sup>3</sup> , 220 KW (299 PS), 14.3:1, Turbocharge,LLK <b>Vehicle:</b> F 10 Intercooler, N 10 Intercooler 1983...  <b>Diesel Motor:</b> TMD 102 A, 9599 cm <sup>3</sup> , 105-200 KW (141-272 PS), 14.3:1, Turbocharge,LLK <b>Vehicle:</b> Marine Motor 1983...	6	120.65	109.40 -23.15 -1.90 166.40  	52.00 x 106.00	ST	2.385 R MO 3.160 T CR 4.747 C CR	120.65	P 67040 00	  A=120.65 B=134.00 L=296.00 D=147.00 C=11.52 F=3.48
<b>Diesel Motor:</b> THD 100 DB/DC/DD/E/EB/EC, THD 101 G/GD/K, 9600 cm <sup>3</sup> , 160-180-193-203 KW (217-245-260-310 PS), 15:1, Turbocharge, <b>Vehicle:</b> THD 101 KB/MC, 9600 cm <sup>3</sup> , 203-210-228 KW (276-285-310 PS) 15:1, Turbocharge, LLK <b>Vehicle:</b> C 10 M 1981...1986	6	120.65	109.45 -22.20 -1.90 166.45  	52.00 x 106.00	ST	2.385 R CR 3.160 T CR 4.747 C CR	120.65	P 67042 00	  A=120.65 B=134.00 L=296.50 D=147.00 C=11.52 F=3.50

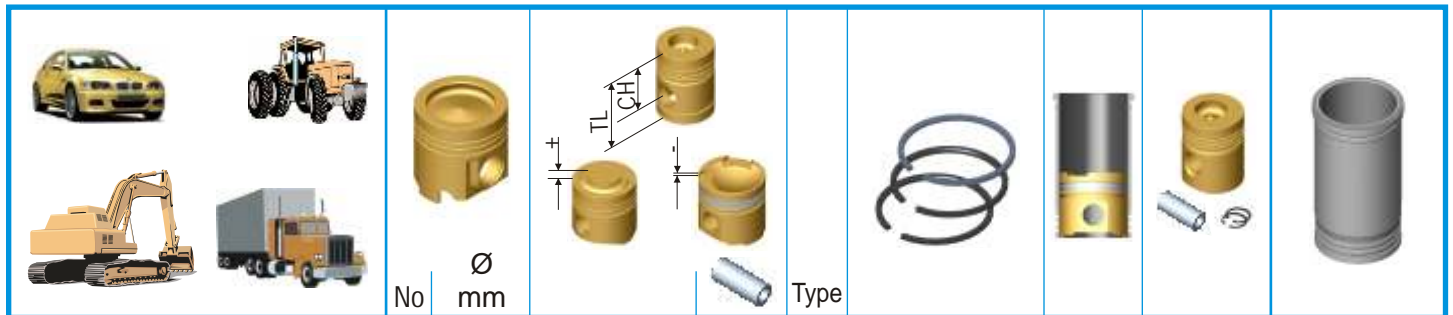

## VOLVO

**Diesel Motor:**  
THD 101 G/GC, 9600 cm<sup>3</sup>,  
180 KW (245 PS),  
15:1  
Turbocharge

**Vehicle:**

B 10 M,

1986...

**Diesel Motor:**

THD 101 K/KB, 9600 cm<sup>3</sup>,  
210 KW (285 PS),  
15:1,

Turbocharge, LLK

**Vehicle:**

B 10 M

1986...1989

**Diesel Motor:**

THD 101 KB/MC, 9600 cm<sup>3</sup>,  
203-210-228 KW  
(276-285-310 PS),  
15:1,

Turbocharge, LLK

**Vehicle:**

C 10 M

1986...

**Diesel Motor:**

THD 101 KC, 9600 cm<sup>3</sup>,  
228 KW (310 PS),  
15:1,

Turbocharge, LLK

**Vehicle:**

C 10 M

1986...1989

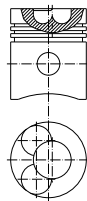

**Diesel Motor:**  
THD 102 KB/KF, 9600 cm<sup>3</sup>,  
210 KW (286 PS),  
16:1,  
Turbocharge, LLK

**Vehicle:**

B 10 M GAB,

...1986

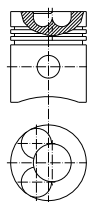

No

Ø  
mm

109.45  
-22.20  
-1.90  
166.45

52.00  
x  
106.00

Type

ST

2.385 R MO  
3.160 T CR  
4.747 C CR

120.65

P 67044 00

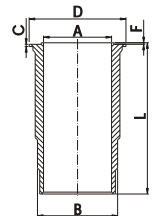

A=120.65  
B=134.00  
L=296.00  
D=147.00  
C=11.52  
F=3.48

6

120.65

109.40  
-20.40  
-1.90  
166.40

52.00  
x  
106.00

ST



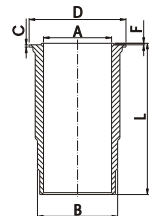

2.385 R MO  
3.160 R CR  
4.747 C CR

120.65

P 67046 00

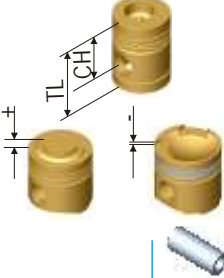



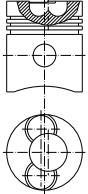
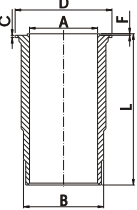
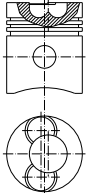
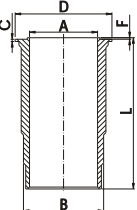
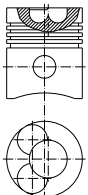
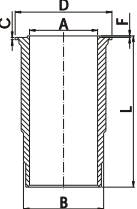

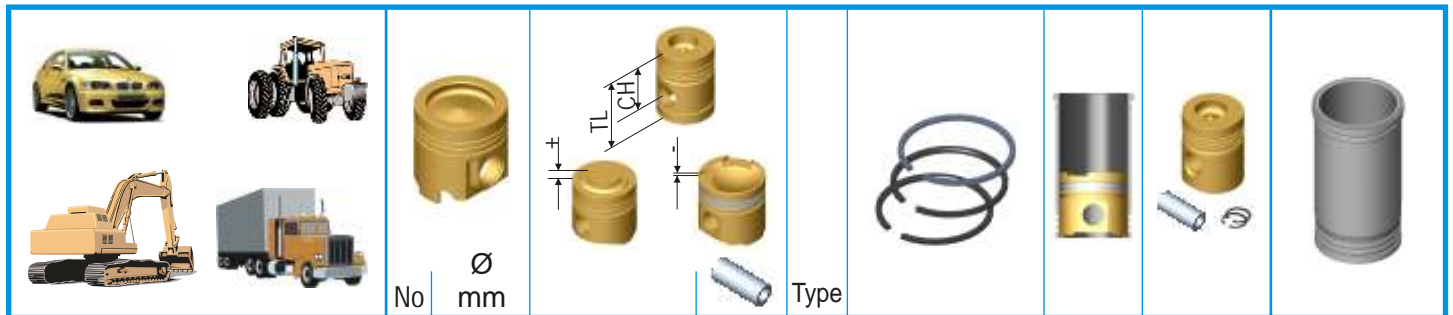

A=120.65  
B=134.00  
L=296.00  
D=147.00  
C=11.52  
F=3.48



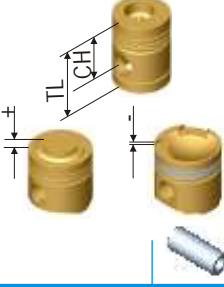

	No	Ø mm			Type				
<b>VOLVO</b>									
<b>Diesel Motor:</b> TD 102 F/FD/FDQ/FF/FQ, 9600 cm <sup>3</sup> , 234 KW (318 PS), 15:1, Turbocharge, LLK <b>Vehicle:</b> F 10,  ...1988	6	120.65	92.55 -22.20 -1.95 132.55  	52.00 x 98.00	ST	3.000 R MO 3.160 T 4.747 C CR	120.65	P 67048 00	  A=120.65 B=133.80 L=287.25 D=147.00 C=11.50 F=3.50
<b>Diesel Motor:</b> TD 102 FL/FM/FH, 9600 cm <sup>3</sup> , 252 KW (343 PS), 16:1, Turbocharge,LLK <b>Vehicle:</b> F 10, FL 10  1990...  <b>Diesel Motor:</b> THD 102 KD, 9600 cm <sup>3</sup> , 250 KW (340 PS), 16:1, Turbocharge,LLK <b>Vehicle:</b> B 10 M  1990...	6	120.65	92.55 -20.40 -1.95 132.55  	52.00 x 98.00	ST	3.000 R MO 3.160 T CR 4.747 C CR	120.65	P 67050 00	  A=120.65 B=133.80 L=287.25 D=147.00 C=11.50 F=3.50
<b>Diesel Motor:</b> D 120, 12000 cm <sup>3</sup> , 176.5 KW (240 PS), <b>Vehicle:</b> F 89  1970...	6	130.18	114.20 -31.74 -1.00 -1.10 175.20  	55.00 x 114.00	ST	2.385 R CR 3.160 T 3.160 T 4.747 C CR	130.18	P 67060 00	  A=130.18 B=143.90 L=311.00 D=157.60 C=13.52 F=0.70



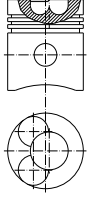
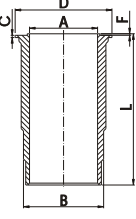
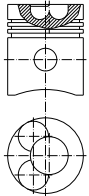
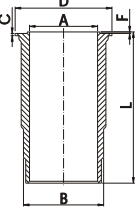
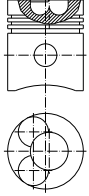
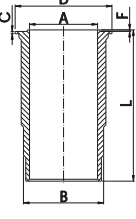

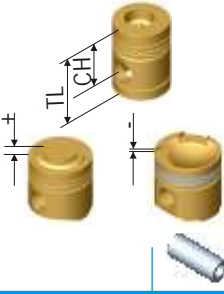

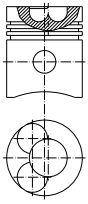
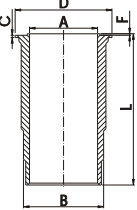
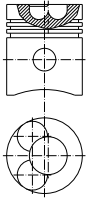
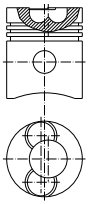
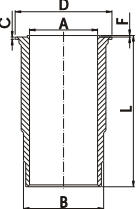

**VOLVO**

	No	Ø mm			Type				
<p><b>Diesel Motor:</b> TD 120 A, 12000 cm<sup>3</sup>, 243 KW (330 PS), 15:1 Strok:150mm Turbocharge <b>Vehicle:</b> F 89, N 12, 1970...1975</p> <p><b>Diesel Motor:</b> TD 120 A, TMD 120 A, 12000 cm<sup>3</sup>, 225-243 KW (306-330 PS), 15:1 Strok: 150mm Turbocharge <b>Vehicle:</b> N 12, CH 230 1977...1981</p>	6	130.18	114.20 -31.55 -1.90 -2.10 175.20	55.00 x 114.00	ST	2.385 R CR 3.160 R CR 4.747 C CR	130.18	P 67062 00	<p>A=130.18 B=143.90 L=311.00 D=157.60 C=13.52 F=0.70</p>
<p><b>Diesel Motor:</b> TD 120 C/D/E, 12000 cm<sup>3</sup>, TAD 120 BHC, 258 KW (350 PS), 13.3:1, Turbocharge <b>Vehicle:</b> F 12-46, F 12-49, F 12-52, F 12-59, F 12-38 1977...1980</p>	6	130.18	114.20 -27.62 -2.50 175.20	55.00 x 114.00	ST	2.385 R CR 3.160 R CR 4.747 C CR	130.18	P 67064 00	<p>A=130.18 B=143.90 L=311.00 D=157.60 C=13.52 F=0.70</p>
<p><b>Diesel Motor:</b> TD 120 F/G/GA, 12000 cm<sup>3</sup>, TAMD 120 AK/B/C/E/BCC, 226.5-243-265 KW (308-330-360 PS), 14.2:1, Turbocharge,LLK <b>Vehicle:</b> F 12 Intercooler, CH 230 T 1980...1984</p>	6	130.18	114.20 -27.95 -2.50 175.20	55.00 x 114.00	ST	2.385 R MO 3.160 T CR 4.747 C CR	130.18	P 67066 00	<p>A=130.18 B=143.90 L=311.00 D=157.60 C=13.52 F=0.70</p>

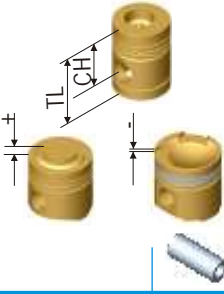
	No	Ø mm			Type				
<b>VOLVO</b>									
<b>Diesel Motor:</b> TD 121 F/G/GD, 12000 cm <sup>3</sup> , TMD 121 C, 243-283 KW (330-385 PS), 14.2:1 Turbocharge, LLK <b>Vehicle:</b> N 12, F 12 1984...1988 Motor No:131 995	6	130.18	114.20 -27.95 -2.50 175.20  Combustion Bowl Ø 79	55.00 x 114.00	ST	2.385 R MO 3.160 T CR 4.747 C CR	130.18	P 67068 00	 A=130.18 B=143.90 L=311.00 D=157.60 C=10.52 F=0.70
<b>Diesel Motor:</b> TAD 121 CHC, 11975 cm <sup>3</sup> , 238 KW (324 PS), <b>Diesel Motor:</b> TAMD 121 C/D, 11975 cm <sup>3</sup> , 217-310 KW (295-420 PS), 14.2:1 Turbocharge <b>Vehicle:</b> Marine Motor 1983...1988	6	130.18	114.20 -27.64 -2.50 175.20  Combustion Bowl Ø 83	55.00 x 114.00	ST	2.385 R MO 3.160 R CR 4.747 C CR	130.18	P 67070 00	 A=130.18 B=143.90 L=311.00 D=157.60 C=10.52 F=0.70
<b>Diesel Motor:</b> TID 121 KG/P, LG/P, KP/B, LP/B, 11979 cm <sup>3</sup> , 217-305 KW (295-415 PS), 13.3:1, Turbocharge,LLK <b>Vehicle:</b> Industrie Motor	6	130.18	114.20 -27.00 -2.50 175.20  Combustion Bowl Ø 83	55.00 x 114.00	ST	3.500 K MO 3.160 R CR 4.747 C CR	130.18	P 67072 00	 A=130.18 B=143.90 L=311.00 D=157.60 C=10.52 F=0.70

	No	Ø mm		Type					
<b>VOLVO</b>									
<b>Diesel Motor:</b> TID 121 FG, 12000 cm <sup>3</sup> , 13.3:1 Turbocharge, LLK <b>Vehicle:</b> Industrie Motor <b>Diesel Motor:</b> TD 122 F, 12000 cm <sup>3</sup> , TAMD 122 A, 262 KW (356 PS) 15:1 Turbocharge, <b>Vehicle:</b> F 12 <b>Diesel Motor:</b> TD 122 FK/FR/FS, 12000 cm <sup>3</sup> , 291 KW (395 PS), 15:1 Turbocharge, LLK <b>Vehicle:</b> FS 10, F 12 GL Intercooler 1988...	6	130.18	114.20 -25.40 -2.60 175.20  Combustion Bowl Ø 79	55.00 x 114.00	ST	2.385 R MO 3.160 T CR 4.747 C CR	130.18	P 67074 00  A=130.18 B=143.90 L=311.00 D=157.60 C=10.52 F=0.70	
<b>Diesel Motor:</b> TID 121, 11979 cm <sup>3</sup> , 270 KW (367 PS), 13.3:1, Turbocharge, LLK <b>Vehicle:</b> Marine Motor 1988...	6	130.18	114.20 -27.00 -2.50 175.20  Combustion Bowl Ø 83	55.00 x 114.00	ST	3.500 R MO 3.160 R CR 4.747 C CR	130.18	P 67076 00	
<b>Diesel Motor:</b> TD 122 F(USA)/FH/FL, 12000 cm <sup>3</sup> , 272 KW (370 PS), 16:1, Turbocharge,LLK <b>Vehicle:</b> F 12, White GMC	6	130.18	114.20 -24.12 -2.60 175.20  Combustion Bowl	55.00 x 114.00	ST	2.385 R P 3.160 T CR 4.747 C CR	130.18	P 67078 00  A=130.18 B=143.90 L=311.00 D=157.60 C=10.52 F=0.70	

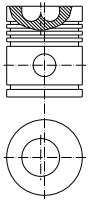
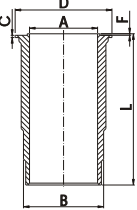
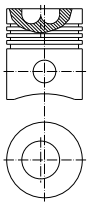
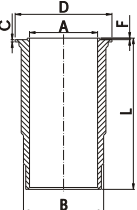
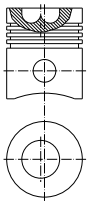
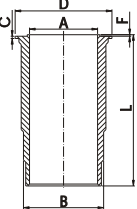
	 No Ø mm		Type			
<b>VOLVO-BM</b>						
<p><b>Diesel Motor:</b> 1051-J/K/G, 1120 cm<sup>3</sup>, 8.5 KW (11.5 PS), 16.5:1</p> <p><b>Diesel Motor:</b> 1052-J/K/G, 2240 cm<sup>3</sup>, 22 KW (30 PS), 16.5:1</p> <p><b>Diesel Motor:</b> 1053-T/K/P/G/GP, 3360 cm<sup>3</sup>, 31.5 KW (42.5 PS), 16.5:1</p> <p><b>Diesel Motor:</b> 1054-T/J/K/P/G/GP, 4480 cm<sup>3</sup>, 42 KW (57 PS), 16.5:1</p>	1 104.775  2  3  4	85.50 -24.5 148.10  	40.00 x 86.40	2.385 R CR 3.160 T 3.160 T 4.747 BS 4.747 BS	104.775 P 68010 00	  A=104.775 B=117.00 L=258.50 D=124.90 C=12.00 F=0.75
<p><b>Diesel Motor:</b> D 42, 4200 cm<sup>3</sup>, 59 KW (80 PS), 17.5:1</p> <p><b>Vehicle:</b> 650, Lader LM 621, LM 641 1970...1975</p>	4 105.57	84.10 -23.10 135.10  	40.00 x 88.50	2.385 R CR 3.160 T 3.160 T 4.747 C CR	105.57 P 68020 00	  A=105.57 B=118.00 L=245.00 D=127.50 C=14.00 F=0.75
<p><b>Diesel Motor:</b> TD 42, 4200 cm<sup>3</sup>, Turbocharge  1976...</p>	4 105.57	84.10 -24.85 135.10  	42.00 x 87.00	ST 2.385 R CR 3.160 T 3.160 T 4.747 C CR	105.57 P 68022 00	  A=105.57 B=118.00 L=245.00 D=127.50 C=14.00 F=0.75